

**SERIES AP5102
DIN-Rail Conditioner for LVDTs**



ISO 9001:2000

INDEX

1. INTRODUCTION	2
2. INSTALLATION INSTRUCTIONS	3
2.1 EMC Requirements	3
2.2 Unit Mounting	3
2.3 Connections General	4
2.4 Internal Controls	5
2.5 Transducer connections (LVDT and half bridge)	6
3. CONTROLS	6
3.1 Voltage/Current Output	6
3.2 Coarse Gain Selection	6
3.3 Fine Gain (On front panel, labelled GAIN)	6
3.4 Coarse Zero	6
3.5 Zero Input	7
3.6 Fine Zero (On front panel, labelled ZERO)	7
3.7 Over-Range Indicator	7
3.8 Excitation Voltage	7
3.9 Excitation Frequency	7
3.10 Master/Slave	7
4.0 SETTING UP PROCEDURES	8
4.1 LVDT & Half Bridge (Differential Inductance) Transducers	8
5. SPECIFICATION	9
6. WARRANTY	10

1. INTRODUCTION

The AP5102 is a single channel signal-conditioning unit for use with transducers requiring AC excitation and synchronous demodulation, producing a DC output voltage or current.

The AP5102 incorporates a DC-DC converter ensuring that the output of the unit is electrically isolated from the supply.

Units may be master-slaved in systems where carrier frequency beating is a problem.

The unit is housed in a DIN-rail mounting thermoplastic case with recessed screw-clamp terminals for all connections and 25-turn front-panel-accessible span and zero adjustments.

All other controls are internal including coarse gain and zero switches, a zero input switch and jumper links for master/slave setting and excitation frequency setting.

The unit is suitable for use with the complete range of STI LVDT transducers.

2. INSTALLATION INSTRUCTIONS

2.1 EMC Requirements

For optimum EMC performance use shielded multi-core cables for connection to this instrument; the cable shield may be terminated by means of a short "pig-tail" and connected to the terminals marked:

- (a) Pin 5 – Transducer cable
- (b) Pin 15 – Supply/Output cable

The DIN-rail to which the unit is attached should be grounded.

The screw clamp terminals can accept either solid or stranded wire sizes from 0.2 mm (24 AWG) to 2.5 mm (12 AWG).

NOTES:

1. Cable shields to be grounded at only one end - the AP5102 end, although grounding at both ends may reduce the effects of high frequency EMI.
2. When the AP5102 is a small part of a large electrical installation, ensure the cables to and from the AP5102 are segregated from electrically noisy cables.
3. Ensure cables to and from the AP5102 are routed away from any obviously powerful sources of electrical noise, e.g. electric motor, relays, solenoids.
4. ESD precautions should be used when working on the instrument with the lid removed. The user should ensure he is "grounded" by use of an grounded wrist strap or at least touching ground before touching any component including wires, terminals or switches.
5. The transducer body should be grounded. Some transducers such as LVDTs, load cells, etc. without an internal body-to-shield connection, require a separate ground. This should preferably be connected to the instrument shield terminal or as near (electrically) as possible to this point.

2.2 Unit Mounting

The AP5102 housing is a standard DIN rail enclosure which can clip directly to a 35 mm top hat rail. The units can be mounted side by side if in an ambient temperature up to 105°F. Above this temperature, a gap of 15 mm should be left in between each unit.

2.3 Connections General

Transducer, supply and output connections are made by 4 x 4 way screw-clamp terminals as shown in Fig 1.

To reverse output polarity, reverse signal hi/signal lo. Voltage output is between Volts Out and common, current output is between current out and common. Output common is internally connected to Excitation Lo.

WARNING: INCORRECT SUPPLY CONNECTION, e.g. CONNECTING SUPPLY WIRE TO OUTPUT (O/P) MAY DAMAGE THE UNIT AND INVALIDATE THE WARRANTY.

Fig. 1 Connections



1	Excitation Hi
2	Excitation Lo
3	Signal Lo
4	Signal Hi
5	Screen
6	Master
7	Slave
8	m/s comm
9	Volts Out
10	Common
11	Common
12	Current Out
13	Supply +
14	Supply -
15	Screen
16	N/C

2.4 Internal Controls

To access internal controls the front part of the AP5102 case needs to be removed. To do this, use a small screw driver to gently press in the clips behind terminal 1-4 and 13-16. At the same time pull forward the front of the case. The front of the case and pcb assembly should now slide forward.

It will usually only be necessary to make changes to Gain and Zero controls.

Fig. 2 Internal Controls

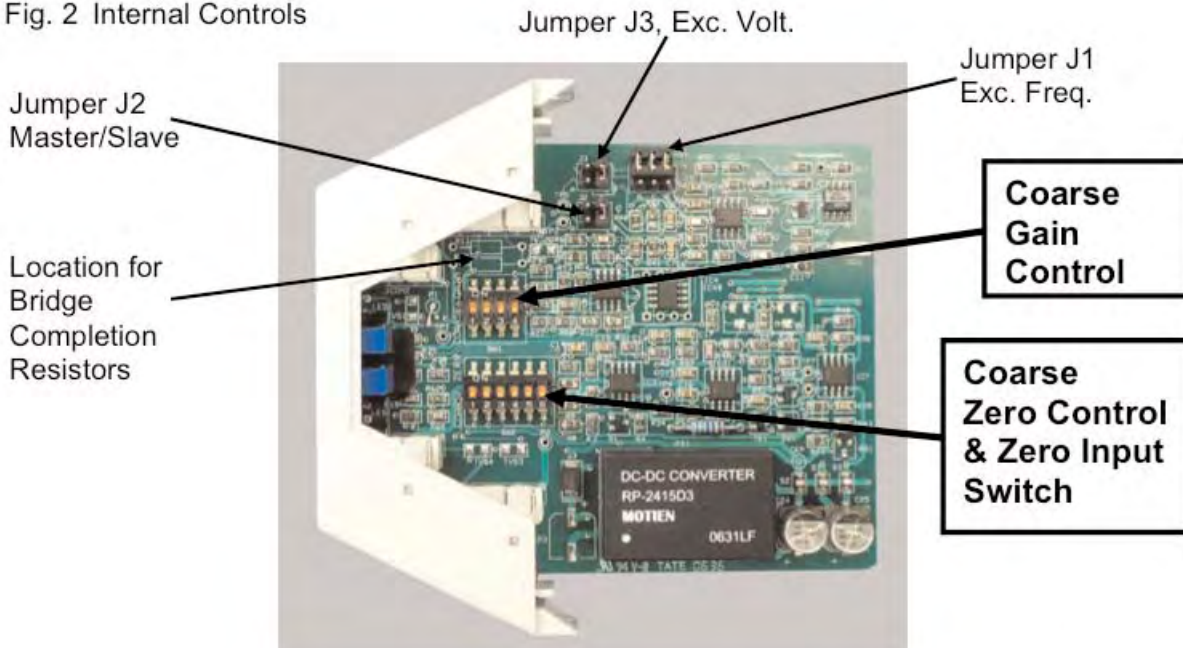

To put case back together, gently slide pcb assembly into case guide slots. Ensure pcb ground pad CG1 is lined up with the ground clip inside the case, and push back until the front of the case clicks back into place.

2.5 Transducer connections

Fig. 3a LVDT transducer connections.

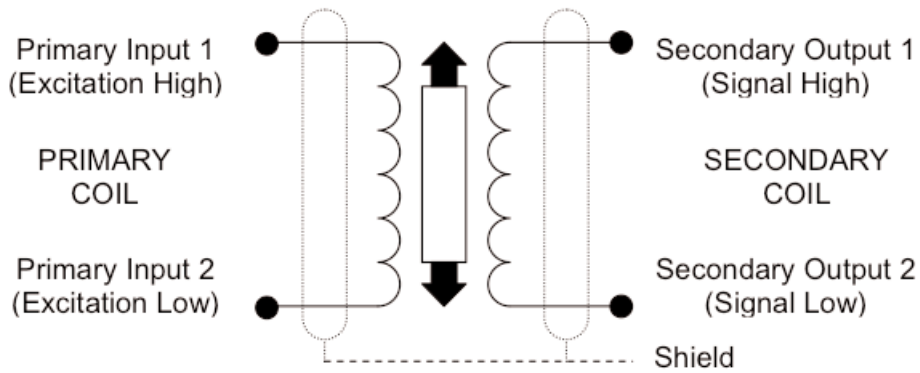

See fig. 1 for pin designations.

Most STI LVDT transducers also have a BLACK wire. This is not required with the AP5102 amplifier and should be insulated and left unconnected.

If the above configuration does not give the required output phase (i.e. the output rises for outward transducer movement instead of falling); reverse signal high and signal low connections

Fig. 3b Half bridge (differential inductance) transducer connections.

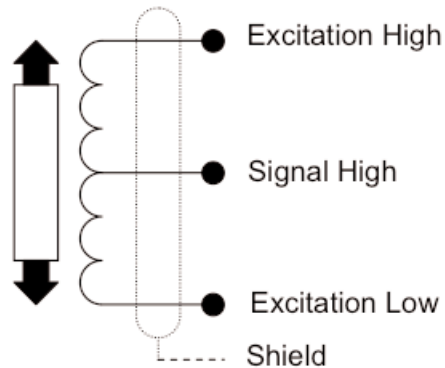

In addition to these connections, it is necessary to add two bridge completion resistors to compensate for the fact that the transducer is only half bridge. For STI transducers, the resistors should be 1k Ohms, high stability. These should be mounted in R11 and R12 locations, as shown in Fig. 2.

If when connected, the phase of the amplifier output is not as required (for example, an inward moving armature causes a rising amplifier output when a falling output is required) then reversing the excitation high and excitation low wires will correct this.

3. CONTROLS

(For locations, see Figure 2)

3.1 Voltage/Current Output

Voltage output is available between pins 9 & 10 (common). Current output is available between pins 12 and 11 (common). Pins 10 and 11 are internally connected.

3.2 Coarse Gain Selection

Typically, transducer manufacturers' data sheets or calibration certificates will give a figure allowing the full-scale output to be calculated. Possible formats for this are as follows; **the examples assume a transducer range of ±50mm.**

Sensitivity format	Explanation	To convert to F.S. output
mV/V/mm e.g. 46mV/V/mm	Millivolts of output, per volt of excitation, per mm of travel	Sensitivity x 1 x range in mm e.g. 0.046 x 1 x 50 = 2.3V
V/V at full-scale, e.g. 2.3 V/V	Volt of output, per volt of excitation, at full-scale	Sensitivity x 1 e.g. 2.3 x 1 = 2.3V
mV/mm at a specified excitation voltage. E.g. 230mV/mm at 5V exc.	Millivolts of output, per mm of travel, given a specified excitation voltage.	(Sensitivity / specified excitation voltage) x 1 x range in mm e.g. (0.230/5) x 1 x 50=2.3V

The standard excitation of the AP5102 is 1V, as used in the calculations above.

The following table shows the band of transducer full-scale output voltages appropriate to each of the 8 Gain Range Settings. For example, a transducer with a full-scale output of 2.3V would be correctly set as gain range 3 for a ±5V DC output..

An 4-way toggle switch, SW1, sets the overall gain in the ranges shown below:

SW1 toggles ON	Gain Range	Gain Range (Approximate)	Recommended Input		
			For ±5V O/P	For 4-20mA O/P	For ±10V O/P (note 2)
1	1	X0.07 to 0.25	4V max	4V max	4V max
1+2	2	0.25 to 0.7	4V max	4V max	4V max
1+3	3	0.7 to 2.5	2-4V max	1.7-4V max	4V max
1+4	4	2 to 6	0.8-2.5	0.7-2	1.6-4V max
NONE	5	5 to 20	0.3-1	0.22-0.8	0.6-2
2	6	17 to 50	0.1-0.3	0.07-0.25	0.2-0.6
3	7	50 to 170	0.03-0.1	0.02-0.08	0.06-0.2
4	8	170 to 500	0.01-0.03	-	0.02-0.06

3.3 Fine Gain (On front panel, labeled GAIN)

A screwdriver-adjusted, 25-turn potentiometer providing a 4:1 adjustment of gain, interpolating between the ranges set by the GAIN RANGE switch.

3.4 Coarse Zero

A 5-way toggle switch, SW2, (toggle 6 – see section 3.5) provides output zero shifts of about 1V per step (with Fine Gain at minimum – up to 4V at maximum). When used with FINE ZERO will suppress any output (up to 5V) to zero. All toggles OFF is normal, ie no suppression applied. Switching toggle 1 ON with toggles 3, 4 or 5 will suppress positive outputs. Switching toggle 2 ON with toggles 3, 4 or 5 will suppress negative outputs. The suppression increases when toggles 3, 4 or 5 are switched ON.

3.5 Zero Input

SW2 toggle 6 which, when switched to ON, zero's the signal, input voltage to the amplifier irrespective of transducer position. This enables a true amplifier zero to be realised.

3.6 Fine Zero (On front panel, labelled ZERO)

A screwdriver-adjusted, 25-turn potentiometer allowing adjustment of output zero by $\pm 1\text{v}$ to $\pm 4\text{v}$ depending on Fine Gain setting. Used with 3.3 will provide up to 100% suppression.

3.7 Over-Range Indicator

A red lamp that indicates when the demodulator input exceeds the linear range.

3.8 Excitation Voltage

Units are normally supplied with 1V excitation. This can be changed to 3V by changing J3 to B-C.

3.9 Excitation Frequency

Fig 4. Excitation Frequency

If necessary, excitation frequency can be changed by moving J1 as shown.

Figure 2 shows the location of J1.

Other excitation frequencies are available if stated when ordering.

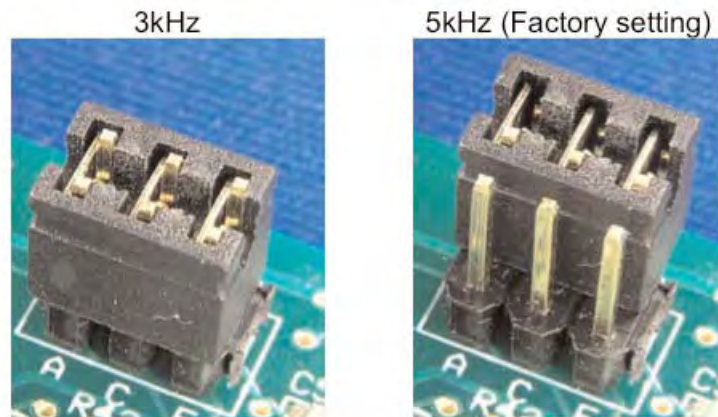

3.10 Master/Slave

The unit may be configured as a master oscillator or slave oscillator by the setting of J2.

For Master oscillator (Factory Default)	link J2	B-C	See Fig 2 for the
For Slave units	link J2	A-D	location of J2

Link terminal 6 on the MASTER unit with terminal 7 on the SLAVES and link terminal 8 on all units as shown below:

Fig 5. Master/Slave Connections

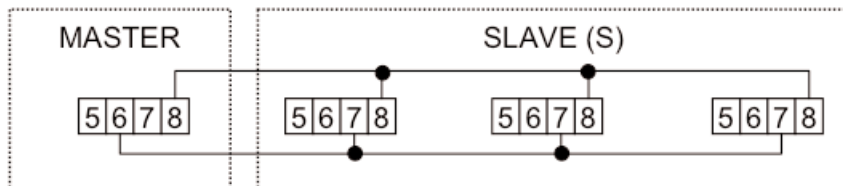

4.0 SETTING UP PROCEDURES

4.1 LVDT & Half Bridge (Differential Inductance) Transducers

- 4.1.1 Determine the transducer full scale output from the manufacturer's data sheet and set the Coarse Gain control as shown in Sections 3.
- 4.1.2 Connect the transducer to the 4-way connector as detailed in Section 2. Switch ON power and allow a 15-minute warm-up period (for maximum accuracy).
- 4.1.3 Switch on the ZERO INPUT switch (SW2 toggle 6) and adjust the ZERO controls on the AP5102 for either 0 volts or 12 mA output (depending on which output is being used). Switch off the ZERO INPUT switch.
- 4.1.4 Adjust the transducer armature for either 0 volts or 12 mA output from the AP5102. The FINE ZERO control may be used to obtain an absolute zero indication if the armature adjustment is too coarse.

Now proceed with either 4.1.5 or 4.1.6 according to application.

4.1.5 Bipolar Operation (e.g. $\pm 5V$ or 4-20mA)

- (a) Move the transducer armature by a precise amount (e.g. 5mm for a LMS60X transducer) and adjust the FINE GAIN control for the desired output, e.g. 5v, or 20mA.
- (b) Relocate the transducer armature at the centre of the stroke and check that the output is zero. Re-adjust the FINE ZERO control if necessary.

Repeat (a) and (b) for consistent results.

- (c) Move the armature to the full-scale position in the opposite direction and check for example -5v or 4mA output.

4.1.6 Unipolar Operation (e.g. 0 to 10V)

If it is required that the transducer be used over its entire working range in the one direction, e.g. 0 to 10mm for a LMS60X transducer, then the zero controls are used to "back-off" the signal equivalent to 5mm, then:-

- (a) Set up as in 4.1.5, i.e. $\pm 5V$ output for $\pm 5mm$ using a LMS60X.
- (b) Move the armature by exactly 5mm (for a LMS60X transducer) and then adjust the ZERO controls to back off this signal to zero. Now move the armature back 10mm and adjust the FINE GAIN control for the required output.
- (c) Repeat (b) until consistent results are obtained. If, for any reason, the coarse gain is changed, restart the whole procedure.

5. SPECIFICATION

Supply	9 to 36 V DC 250 mA max (Isolated from output)
Voltage Output	±10V into 2k ohm
Current Output	4-20mA into 100/550 ohm max. Overload internally limited to 30mA max.
Oscillator Output	1V rms. at 5kHz standard. 25mA maximum. 3Vrms and 3 kHz also available.
Oscillator Temperature Coefficient	0.003%/°F typical
Demodulation	Synchronous
Amplifier Gain	X0.07 to X500 in 8 ranges with fine control interpolation
Zero Range	±5V minimum
Linearity	0.05% of full scale
Input Resistance	130k ohm differential
Zero Stability	
Voltage Output	0.001% of FS typical/°F
Current Output	0.003% of FS typical/°F
Gain Stability	
Voltage Output	0.003% of FS typical/°F
Current Output	0.05% of FS typical /°F
Bandwidth	DC to 250Hz (flat)
Noise	
Voltage Output	5mV RMS
Current Output	20 µA RMS typical
EMC Specification	When subjected to radiated electro-magnetic energy (as EN61000-4-3) an additional error can occur at certain frequencies:
	Field Strength Typical Maximum Error
	10V/m 1.5%
	3V/m 0.1%
Temperature Range	+14°F to +140°F
Dimensions	4.51 x 0.89 x 3.90 inches
Weight	4.4 oz
Seals	IP20 specification

WARRANTY: Stellar Technology warrants that its product shall be free from defective workmanship and/or material for a twelve month period from the date of shipment, provided that Stellar Technology's obligation hereunder shall be limited to correcting any defective material FOB our factory. No allowance will be made for any expenses incurred for correcting any defective workmanship and/or material without written consent by Stellar Technology. This warranty is in lieu of all other warranties expressed or implied.



237 Commerce Drive • Amherst, NY 14228 • USA
Tel: 716.250.1900 • **Fax:** 716.250.1909
Email: info@stellartech.com